

# DTX-PLA002S

## 10 Gigabit Permanent Link Adapters

### Instruction Sheet

The DTX-PLA002S is a set of two permanent link adapters for use with a Fluke Networks DTX CableAnalyzer™ tester. The adapters let you test and certify installed permanent links to proposed ANSI/TIA/EIA Cat 6A standards and verify that links will support 10 Gigabit Ethernet applications.

The adapter's minimal effect on test results ensures that your results exceed the accuracy and repeatability specifications given in the proposed TIA-568-B, ISO 11801, and IEEE 802.3an (10GBASE-T) standards.

#### Handling and Operational Information

##### Caution

To avoid damaging the adapter and to ensure maximum accuracy of test results:

- Never pinch, kink, or crush the adapter's cable. Follow the handling guidelines given in Figures 1 and 3.
- Never connect the adapters to telephone lines of any type, including ISDN lines. Doing so can damage the adapters and the tester.
- Always turn on the tester before connecting it to a link. Doing so activates the tool's input protection circuitry.
- Before using a DTX tester, read the complete list of safety and operational information given in the product's documentation.

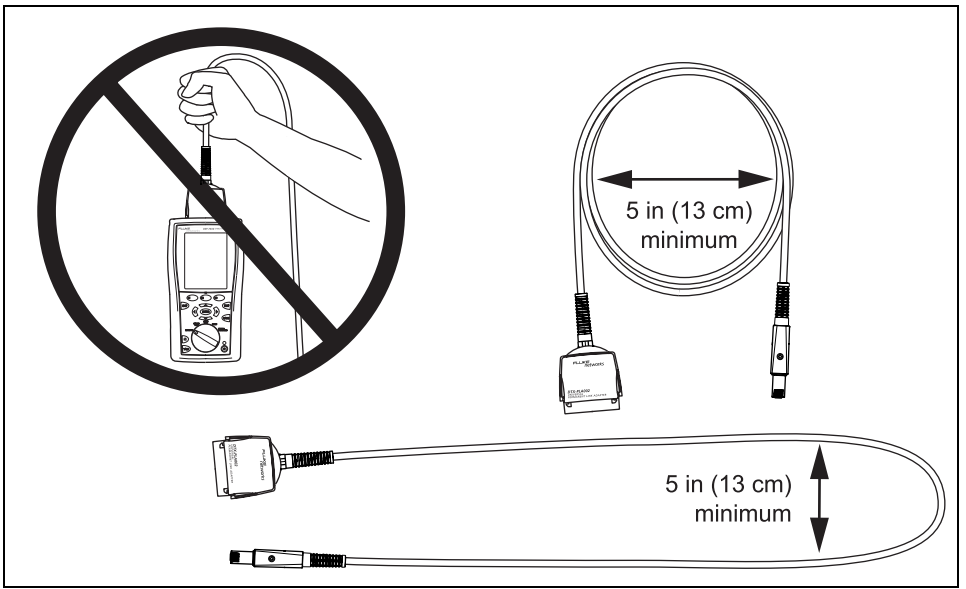

eiyo1.eps

Figure 1. Handling Guidelines

## Using the Permanent Link Adapters

### Note

*The DTX main and remote testers must have software version 1.31 or later to work with the DTX-PLA002 adapters. Software upgrades are available on the Fluke Networks website.*

Figure 2 shows typical connections to a permanent link. Be sure to select the test standard appropriate for the link under test. Refer to the tester's users manual or contact Fluke Networks for additional information.

### Note

*To disconnect the plug from a patch panel, pull on the plug's case as shown in Figure 3. You do not need to depress the latch to disconnect the plug.*

### Caution

**To avoid damaging the adapter, never pull on the strain relief to disconnect the plug from a patch panel. See Figure 3.**

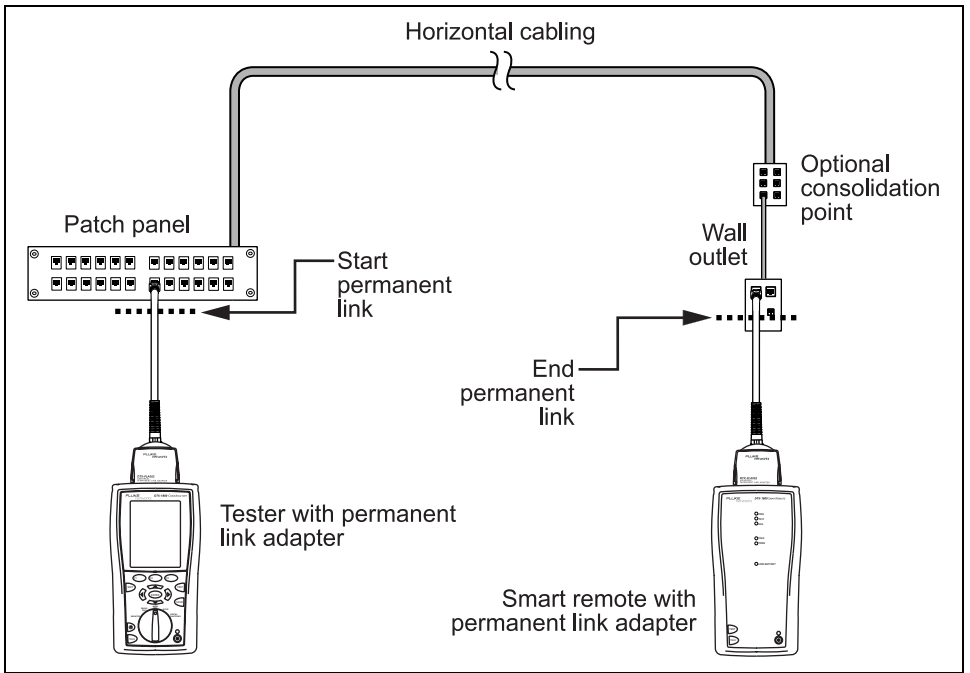

eiyo2.eps

**Figure 2. Connecting to a Permanent Link**

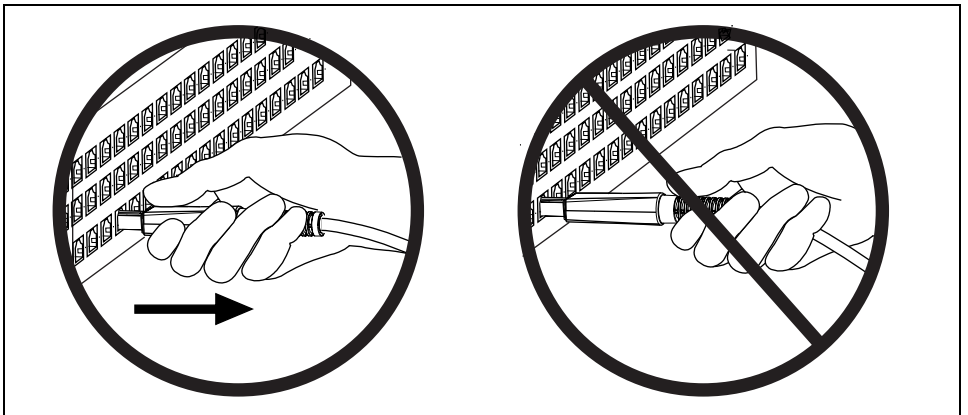

eiyo3.eps

**Figure 3. Disconnecting the Plug from a Jack**

## Maintenance and Service

Clean the adapters with a soft cloth dampened with water or water and a mild soap. Do not use abrasives, solvents, or alcohol.

For the most current test standards, new features, and other enhancements, keep your tester's software up to date. The latest version of software is available on the Fluke Networks website.

If an adapter does not work properly, check for damage to the connectors or cable. Verify that the adapter is securely latched to the tester.

The adapters should be serviced only by a qualified technician. Contact Fluke Networks for the location of the nearest service center.

### Replacing the Tip or Latch

Replace the tips when test result margins begin to shrink or if a tip is damaged. The Autotest counter on the tester's version information screen is useful for tracking the number of insertions.

The plug's latch may also wear out over time. The kit listed under "Options and Accessories" provides replacement tips and latches.

## Options and Accessories

Description	Fluke Networks Model Number
Set of 2 tips, 2 latches, 2 screws, and 2 conductive washers for DTX-PLA002 Permanent Link Adapters	DTX-PLA002PRP

# Contacting Fluke Networks



[www.flukenetworks.com](http://www.flukenetworks.com)



[support@flukenetworks.com](mailto:support@flukenetworks.com)



+1-425-446-4519

- Australia: 61 (2) 8850-3333 or 61 (3) 9329-0244
- Beijing: 86 (10) 6512-3435
- Brazil: 11 3044 1277
- Canada: 1-800-363-5853
- Europe: +44-(0)1923-281-300
- Hong Kong: 852 2721-3228
- Japan: 03-3434-0510
- Korea: 82 2 539-6311
- Singapore: 65 6799-5566
- Taiwan: (886) 2-227-83199
- USA: 1-800-283-5853

Visit our website for a complete list of phone numbers.

## Specifications

The DTX-PLA002 Permanent Link Adapter meets all proposed measurement accuracy specifications for Level IV test equipment. Visit the Fluke Networks website for performance characteristics and additional information.

**Life of module contacts (typical): >5,000 cycles**

Certifications:   

**Dimensions:** 4.57 in x 2.13 in x 1.81in (11.6 cm x 5.4 cm x 4.6 cm) with 5 ft (1.5 m) cable

**Weight:** 6.6 oz (187 g)



Do not put products containing circuit boards into the garbage. Dispose of circuit boards in accordance with local regulations.

## LIMITED WARRANTY AND LIMITATION OF LIABILITY

Fluke Networks mainframe products will be free from defects in material and workmanship for one year from the date of purchase. Parts, accessories, product repairs and services are warranted for 90 days, unless otherwise stated. Ni-Cad, Ni-MH and Li-Ion batteries, cables or other peripherals are all considered parts or accessories. This warranty does not cover damage from accident, neglect, misuse, alteration, contamination, or abnormal conditions of operation or handling. Resellers are not authorized to extend any other warranty on Fluke Networks' behalf. To obtain service during the warranty period, contact your nearest Fluke Networks authorized service center to obtain return authorization information, then send your defective product to that Service Center with a description of the problem.

THIS WARRANTY IS YOUR ONLY REMEDY. NO OTHER WARRANTIES, SUCH AS FITNESS FOR A PARTICULAR PURPOSE, ARE EXPRESSED OR IMPLIED. FLUKE NETWORKS IS NOT LIABLE FOR ANY SPECIAL, INDIRECT, INCIDENTAL OR CONSEQUENTIAL DAMAGES OR LOSSES, ARISING FROM ANY CAUSE OR THEORY. Since some states or countries do not allow the exclusion or limitation of an implied warranty or of incidental or consequential damages, this limitation of liability may not apply to you.

Fluke Networks  
PO Box 777  
Everett, WA 98206-0777  
USA